

Socket End Resilient Gate Valve For PVC Pipe

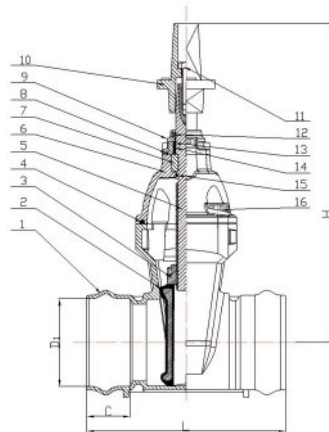

APPLICATION

SIZE	DN50-300
CLASS	PN 10/16 CL125/150
DESIGN	EN1171,EN10742,AS2638
FACE TO FACE	EN558-1
END FLANGE	EN1092-2
TESTS	EN12266

MATERIAL LIST & DIMENSIONS.

STANDARD MATERIALS OF MAIN PARTS			
ITEM	PART NAME	MATERIAL	STANDARD
1	Body	GGG50/GJS500	DIN 1693/BS EN 1563
2	Disc	GGG50/EPDM	DIN 1693/BS EN 1563
3	Stem Nut	CuZn39Pb1/C37000	EN 12167/ASTM B135
4	Bonnet Gasket	NBR	ISO4633
5	Stem	X20Cr13/420	EN 10088-1/ASTM A959
6	Bonnet	GGG50/GJS500	DIN 1693/BS EN1563
7	Holding Ring	CuZn39Pb1/C37000	EN 12167/ASTM B135
8	O Ring	NBR	ISO4633
9	Gland	GGG50/GJS500	DIN 1693/BS EN 1563
10	Cap	GGG50/GJS500	DIN 1693/BS EN 1563
11	Bonnet Bolts	C45E/1045	EN 10083-2/ASTM A29
12	Stem Ring	NBR	ISO4633
13	O Ring	NBR	ISO4633
14	Washer	Nylon 66	\
15	U Ring	EPDM	ISO4633
16	Screw	C45E/1045	EN 10083-2/ASTM A29

DN	OUTLINE mm			PVC Tube D1
	L	C	H	
50	250	77	270	Φ60/Φ63
65	270	80	310	Φ75
80	280	84	325	Φ85/Φ90
100	300	88	365	Φ110
150	350	94	460	Φ160
200	400	100	560	Φ200/Φ225
250	450	125	650	Φ250
300	500	140	740	Φ315